

Heidra[®] 200 Hydraulic Submersible Pumps

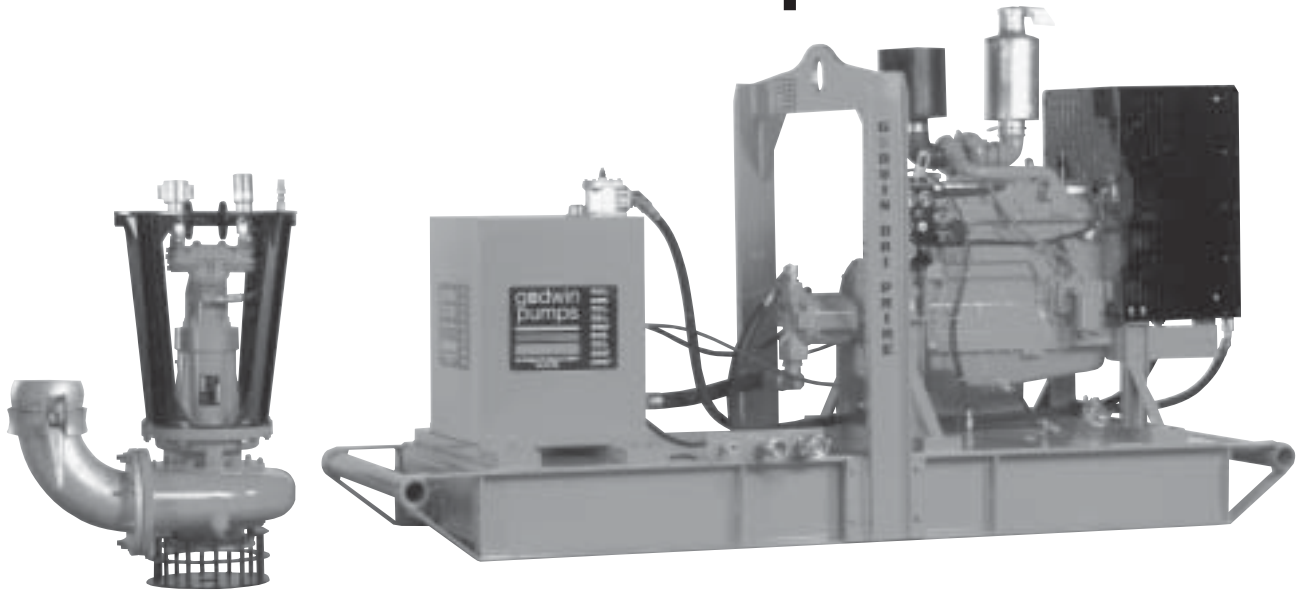

The Heidra 200 hydraulic submersible pump is a self-contained, diesel powered 8" (200mm) pump available for heavy duty municipal and industrial dewatering and solids handling pumping applications. The Heidra 200 offers flow rates up to 3100 gpm (703.7 M³/hr.) with up to 180' (54.9M) of total dynamic head and solids handling capability of 3-1/8" (79mm) in diameter. The unit consists of a sturdy cast iron submersible pumpend and hydraulic power pack mounted on a rugged steel skid. A variable displacement hydraulic piston pump on the power pack delivers hydraulic fluid to a fixed displacement piston motor that drives the pumpend's shaft, bearings, and cast steel impeller. Simple engine throttle adjustments allow changes to pump flow and head performance.

Features

- Rugged construction of cast iron pumpend with cast chromium steel impeller.
- Flow rates to 3100 gpm (703.7 M³/hr.) and heads to 180 feet (54.9M).
- Unique double mechanical seal immersed in isolated oil bath for unlimited dry running capability.
- Integral 175 gallon (662 liter) fuel tank capacity provides over 24 hours of continuous operation.
- Safety shutdown system incorporated into engine controls prevents equipment damage from engine fault or failure.
- Impeller designed for general pumping with solids up to 3-1/8" (79mm) in diameter.
- "Quick-Disconnect" hydraulic fittings simplify setup, installation, and shutdown.
- Standard John Deere 6068T or Caterpillar 3116TA engine. Also available with other diesel engines or electric drive motor.

godwin
pumps



Heidra® 200 Performance Curve

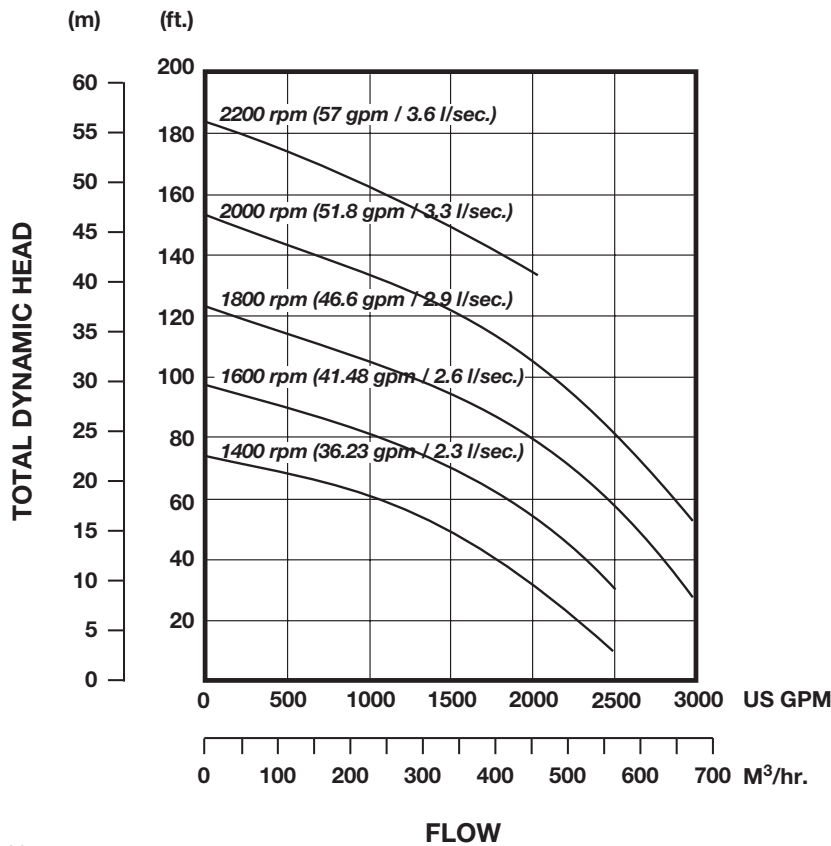

Notes:

1. Impeller diameter: 11-3/8" (290 mm)
2. Performance curves based on diesel engine speed
3. Requires hydraulic system pressure to 4000 psi (276 BAR)

Performance data based on water testing at sea level and 68° F. Larger diameter pipes may be required for maximum flows.

Dimensions

Heidra 200 — shown with John Deere 6068T, Skid Base
 Pump Weight: 780 lbs. (354 kg.)

Complete pumpset is supplied with one each of 1-1/4" X 50' (32mm x 15.25M) high pressure feed and return hoses and one 1/2" X 50' (13mm x 15.25M) low pressure case drain hose.

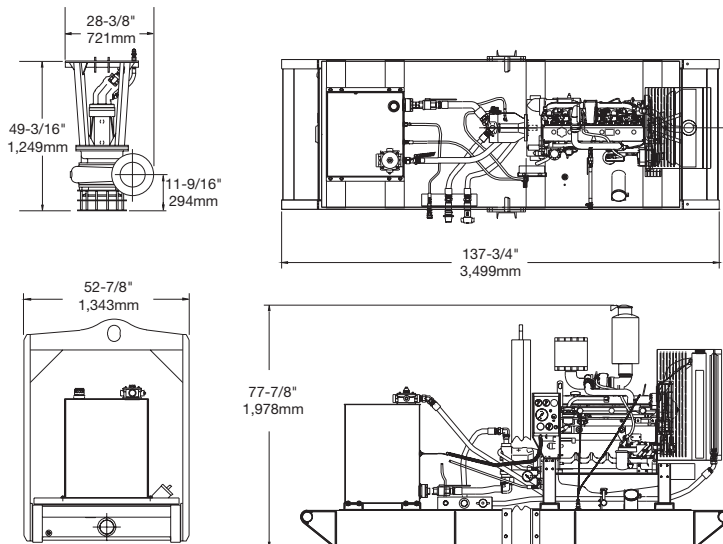

Specifications

Submersible Pump:

- Hydraulic Motor: Fixed Piston
- Drive Pressure: Up to 4000 psi (276 BAR)
- Hydraulic Flow: Up to 57 gpm (3.6 l/sec.)
- Hydraulic Line Length: 100 feet / 30.5M (longer runs with larger hose)
- Solids Handling: Up to 3-1/8" (79mm) diameter
- Pump Speed: Up to 2200 rpm
- Impeller Diameter: 11-3/8" (290mm)
- Discharge Flange: 8" (200mm) ASA 150
- Hydraulic Connections: 1-1/4" (32mm) Quick Disconnect
- Strainer: Nylon coated with 2-3/4" (70mm) apertures

Power Pack:

- John Deere 6068T Engine
 - Horsepower: 147 hp (110 kw) @ 2200 rpm
 - Fuel Consumption: 7.2 gph (27 lph)
- Caterpillar 3116TA Engine
 - Horsepower: 143 hp (107 kw) @ 2200 rpm
 - Fuel Consumption: 7.6 gph (29 lph)
 - Fuel Tank Capacity: 175 gallons (662 liters)
- Output
 - Hydraulic Flow: 57 gpm (3.7 l/sec.)
 - Pressure: 4000 psi (276 BAR)
 - Control: From engine speed and pressure compensated
- Hydraulic System: Two pipe, open circuit
- Reservoir: 80 gallon (303 liters)
- Control Valve: Pressure compensated on/off valve
- Connections: 1-1/4" (32mm) Quick Disconnect feed and return
 1/2" (13mm) Quick Disconnect case drain
- Supply Line: 125 micron, pleated gauze
- Return Line: 20 micron



Aquatech has two facets to help you with your site specific needs.

For all your Rental and Sales needs call

Aquatech Pump and Power

Phone: 905-907-7852
 Fax: 905-907-1701

For full "turn-key" contracting solutions call

Aquatech Dewatering Company

Phone: 905-907-1700
 Fax: 905-907-1701

Email us: info@aquatd.com
 69 Connie Crescent Concord, ON L4K 1L3
 www.aquatd.ca

Heidra® and the color orange for pumps are registered trademarks of Godwin Pumps of America, Inc. Specifications and illustrations are subject to revision without notice. © Copyright 2002-2003 Godwin Pumps of America, Inc. GPASL.050.903